

Findings of the FESAC subpanel on Transformative Enabling Capabilities (TEC)

Panel Leads: R. Maingi, A. Lumsdaine

Panelists: J.P. Allain, L. Chacon, S. Gourlay, C. Greenfield, J. Hughes,
D. Humphreys, V. Izzo, H. McLean, J. Menard, B. Merrill, J. Rapp, O. Schmitz,
C. Spadaccini, Z. Wang, A. White, B. Wirth

Ex-officio: D. Rej (FESAC chair), S. Knowlton (FESAC co-chair)

FES contact: S. Barish

FESAC debriefing
Gaithersburg, MD
Feb. 1, 2017

Summary

- Charge: identify promising Transformative Enabling Capabilities “*that could promote efficient advance toward fusion energy, building on burning plasma science and technology.*”
- Panel formed in Feb./March 2017
 - Representatives from Labs, Universities, Industry
 - Expertise covered range of key technological areas
- Community input via talks (3 meetings) and white papers
 - 67 Talks and 67 White papers
 - Face to face and ZOOM meetings
- Findings: Four Tier 1 TECs (not prioritized), one Tier 2 TEC
 - Foundational and Enabling Activities
- Draft report sent informally to FESAC members and a few community leaders 1/17/18
 - Thank you! We incorporated feedback to extent possible

Working definition of Transformative Enabling Capability (TEC)

- A TEC is a “*game-changing*” idea, toward *revolutionary* and beyond *evolutionary*
- A TEC would dramatically increase the rate of progress towards a fusion power plant
 - Does not have to be a new idea, but can be one where rapid pace of progress is driven by other fields
 - We have grouped several exciting technologies to form the TECs that are presented in the report

Outline

- Introduction and process
- First Tier Transformative Enabling Capabilities
 - Advanced algorithms
 - High critical-temperature superconductors
 - Advanced materials
 - Novel technologies in tritium fuel cycle control
- Second Tier Transformative Enabling Capability
 - Fast flowing liquid metal plasma-facing components
- Foundational and Enabling Activities

Charge

- The FESAC was recently charged “*to identify the most promising transformative enabling capabilities for the U.S. to pursue that could promote efficient advance toward fusion energy, building on burning plasma science and technology.*”
- The charge lists sample focus areas including “*liquid metals, additive manufacturing, high critical-temperature superconductors, exascale computing, materials by design, machine learning and artificial intelligence, and novel measurements.*”
 - Note that these were examples
 - The committee accepted community input on any “*promising transformative enabling capabilities*” that promote efficient advance toward fusion energy

Charge Note and Panel breakdown

- Note that this activity is an assessment of (multiple) technical capabilities, and not an evaluation of confinement devices. According to the charge “Identification of R&D that may have general impact that both includes and extends beyond” tokamak and stellarator concepts “is welcome. However an assessment of various types of confinement devices is not to be performed.”
- The TEC subcommittee (R. Maingi, Chair, and A. Lumsdaine, Vice-Chair, full membership listed below) was sub-divided into three sub-panels corresponding to different areas of technology application:
 - Plasma Diagnostics, Actuators, and Control
 - Plasma Materials Interaction
 - Reactor and Balance of Plant

TEC Panel membership (1 of 2)

- Rajesh Maingi* (PPPL) & Arnie Lumsdaine* – Chair and Vice-Chair
- Don Rej* (LANL) & Steve Knowlton* (Auburn – emeritus) – FESAC ex-officio members
- Sam Barish (FES) – FES liaison
- **Plasma Materials Interaction (Material science and engineering)**
 - *Jean-Paul Allain (U. Illinois) – sub-panel lead*
 - Juergen Rapp* (ORNL)
 - Oliver Schmitz (UW-M)
 - Chris Spadaccini (LLNL)
 - Zhehui (Jeff) Wang (LANL)
 - Brian Wirth* (UT-K)

* FESAC members

TEC Panel membership (2 of 2)

- **Plasma Diagnostics, Actuators, and Control (Physics and computation)**
 - *Anne White* (MIT) – sub-panel lead*
 - Luis Chacon (LANL)
 - Steve Gourlay (LBNL)
 - David Humphreys (GA)
 - Val Izzo (UCSD)
- **Reactor and Balance of Plant (Mechanical, electrical, and nuclear engineering)**
 - *Charles Greenfield* (GA) – sub-panel lead*
 - Jerry Hughes (MIT)
 - Harry McLean (LLNL)
 - Jon Menard (PPPL)
 - Brad Merrill (INL)

* *FESAC members*

Previous reports and Community input details

- In addition to ReNeW, other recent reports used:
 - 2007 Greenwald panel report
 - 2012 FESAC report and white papers on “Materials Science and Technology Research Opportunities Now and in the ITER Era”
 - 2012 Fusion Nuclear Science Pathways Assessment report (PPPL)
 - 2013 FESAC report and white papers on “Prioritization of Proposed Scientific User Facilities for the Office of Science”
 - 2014 FESAC report and white papers on “Strategic Planning”
 - 2015 Community Workshop reports
- Community submitted 67 White papers and presented 67 talks at the three meetings

Community Input Meetings – Panel Q/A Sessions

Three meetings were conducted for community input:

- ✓ **May 30-June 1, 2017 (Rockville, MD):** Community input meeting for Plasma Diagnostics, Actuators, and Control sub-panel, and also for Reactor and Balance of Plant sub-panel
- ✓ **June 20-22, 2017 (Chicago, IL):** Community input meeting for Plasma-Materials Interaction sub-panel
- ✓ **July 19-21, 2017 (PPPL, Princeton NJ):** Final workshop for **all three sub-panels**; one day of community input time
- Panel face-to-face on Sept. 6, 2017 (Gaithersburg, MD)

Working definition of Transformative Enabling Capability (TEC)

- A TEC is a *revolutionary* idea, beyond *evolutionary*; it is a “*game-changer*”. A TEC would dramatically increase the rate of progress towards a fusion power plant.
 - Examples include a substantial increase in fusion performance, enabling device simplification, reduction in fusion system cost or time to delivery, or improvement in reliability and/or safety.
 - In some cases innovations are needed in other areas to fully capitalize on certain TECs.
- Two tiers of TECs were identified:
 - Tier 1: the capability is advancing rapidly e.g. as driven by other fields, and/or the reward/risk ratio is clearly favorable; these are evaluated as very promising TECs.
 - Tier 2: the transformative potential is evident, but risks are more substantial, and/or the rewards may be more difficult to quantify; these are evaluated as promising TECs.

Evaluation Criteria

- The charge asked to “*comment on the promise, level of maturity, development requirements, risks and uncertainties, and time horizon*” and to “*consider global strengths and gaps in identifying areas of particular opportunity for the U.S.*”
- In the call for white papers, authors were asked to address each of these issues.
- The subcommittee used a metric (as a guideline) when evaluating the various technologies and capabilities. This included consideration of:
 - Transformative impact (as compared to current conventional technology)
 - Risks and uncertainties
 - Maturity and development (Technical Readiness Levels – TRLs)
 - Broader impact

Outline

- Introduction and process
- First Tier Transformative Enabling Capabilities
 - Advanced algorithms
 - High critical-temperature superconductors
 - Advanced materials
 - Novel technologies in tritium fuel cycle control
- Second Tier Transformative Enabling Capability
 - Fast flowing liquid metal plasma-facing components
- Foundational and Enabling Activities

Advanced Algorithms

- Advanced algorithms will transform our vision of feedback control of a power-producing fusion reactor from one of basic feasibility to one employing intelligent systems, enabling operation at optimized points whose achievement and sustainment are otherwise impossible
 - TEC includes: mathematical control, machine learning, artificial intelligence, integrated data analysis
 - Mathematical control: solutions that establish the viability of fusion reactor operation will become within reach
 - Machine learning & AI: enable control of fusion plasmas by bridging gaps in understanding of plasma dynamics
 - *Availability of exascale computing will advance high-fidelity and control-level modeling of plasma processes*

Advanced Algorithms Background

- **Control mathematics** provides methods to access optimized and robustly stable plasma operating states (with sufficient but not necessarily complete physics models): **virtually all aspects of operating tokamaks are now enabled by sophisticated controls**
- **Machine learning and AI** can generate useful models and effective controllers to bridge (small) gaps in physics knowledge: **cars drive themselves without explicit knowledge of dynamics behind behavior of other cars and pedestrians**

Control Operating Regime Map

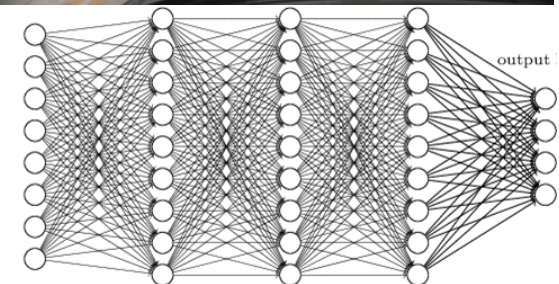
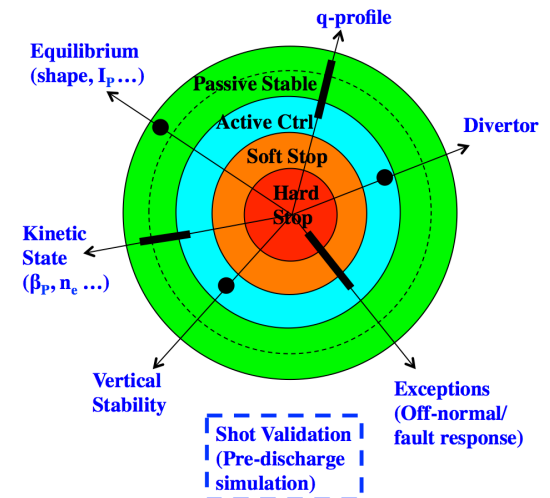

Technology Assessment for Mathematical Control

- History and Status:
 - Control advancements have been a key source of transformational breakthroughs that enable new technologies:
 - Heavier-than-air-flight, complex industrial processes, driverless cars
 - Mathematical control key to advanced fusion device feedback control
- Promise:
 - Advancement of mathematical control design for fusion will accelerate physics understanding and enable sustained achievement of optimized reactor regimes
 - Connections between control-mathematics experts and the fusion community can accelerate progress
- Risk and Uncertainty:
 - Potential for insufficient matching research to produce needed physics models for control development and application

Technology Assessment for Machine Learning and AI

- **History and Status:**
 - Machine learning (ML) and AI are relatively new fields energized by advances in computational capabilities and nonlinear mathematics
 - Recent advances have leaped from limited human-programmed vehicles to fully autonomous commercial cars and trucks in 20 years
- **Promise:**
 - ML and AI offer methods for generating useful models and effective controllers even in the presence of gaps in physics knowledge
 - Fields offer potential for extracting explicit physics understanding from very large collections of data
- **Risk and Uncertainty:**
 - Potential for insufficiently effective connection between fusion community and ML community for new tools and methods
 - Potential for insufficient connection between fusion high performance computing community/research and ML/AI communities and research

Technology Assessment for Offline and Real-time Data Handling Algorithms

- **History and Status:**

- Integrated Data Analysis (IDA) and high-speed simulation are relatively new fields made possible by recent advances in computational capabilities, networks, and embedded systems
- Integration of multiple data sources accomplished by hand, now dramatically expanded to large-scale and automated data integration (impossible by hand)

- **Promise:**

- Systematic methods for offline and real-time data handling have potential to transform data quality and accelerate physics understanding for fusion
- IDA can aid in extracting explicit physics understanding from very large collections of data, enhance confidence, and support verification and validation

- **Risk and Uncertainty:**

- Potential for insufficiently applying systematic data methods to derive benefits

Outline

- Introduction and process
- First Tier Transformative Enabling Capabilities
 - Advanced algorithms
 - High critical-temperature superconductors
 - Advanced materials
 - Novel technologies in tritium fuel cycle control
- Second Tier Transformative Enabling Capability
 - Fast flowing liquid metal plasma-facing components
- Foundational and Enabling Activities

High critical-temperature superconductors

- Advances in higher critical temperature and/or higher field superconductors present a game changing opportunity to enhance the performance and feasibility of reactor designs
 - SC magnets are the essential enabling technology for magnetic confinement fusion
 - Advantages for designing fusion reactors with high magnetic fields
 - Transformative potential comes from the ability to achieve magnetic fields well beyond currently available technology, potentially reducing the time and cost for fusion science research toward power generation
 - Higher magnetic fields could result in more compact burning plasma experiments
 - Operation at temperatures higher than conventional low temperature superconductors raises the prospect of using demountable magnetic field joints

High critical-temperature superconductors - background

Two primary HTS materials with sufficient maturity

- REBCO tapes (main focus for Fusion)
 - Current densities an order of magnitude higher than LTS
 - Has achieved fields over 40 T in solenoids (2x over target for high field designs)
 - No heat treatment required
 - Good strain properties
- Bi-2212 round strands
 - High current density
 - High current cable
 - Complex heat treatment
 - Strain sensitive
 - Possible use in pulsed systems

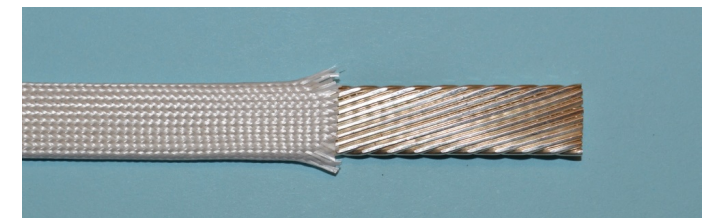
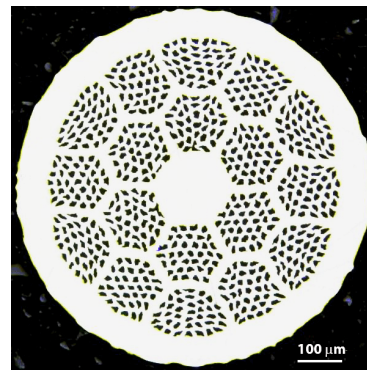
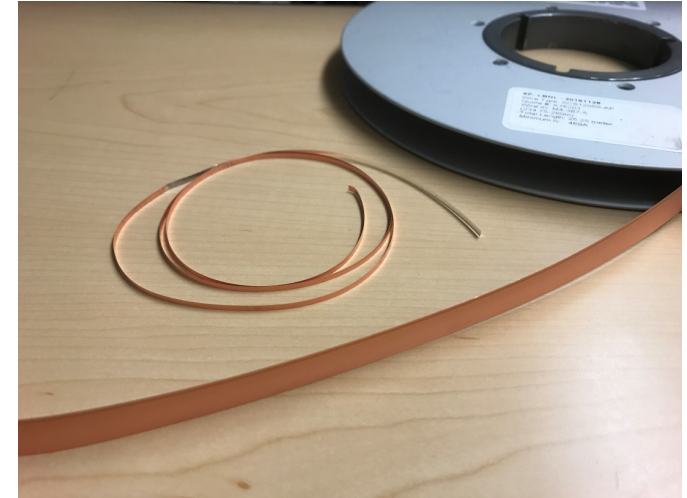

Operating temps at 20 – 30K

REBCO Technology Assessment - Promise

- Present performance of commercially available REBCO tape is already sufficient for use in practical fusion experimental devices
- High operating temperature and low sensitivity of critical current to temperature will lead to greater magnet operating stability
- Remains superconducting at high stresses, over 600 Mpa, and strains up to 0.45%; 2-3x better than LTS
- Initial radiation sensitivity comparable to Nb-Ti and Nb₃Sn
- Since remaining work is engineering rather than basic R&D, an aggressive focused program could produce a prototype magnet in less than a decade
 - Strong synergy with HEP magnet technology in key areas

REBCO Technology Assessment - Challenges

- Tape is natural for pancake coils but more complex geometries need development.
- Long lengths of conductor now produced but high current cables using multi-tapes are still in prototype stages
- Quench detection and protection of HTS magnets
- Compact device could increase technical challenges in plasma exhaust
- **High COST** (Currently between \$400 – 500/kA-m) – targeting \$10/kA-m
- Significant cost reduction through a combination of
 - Increased production levels
 - Performance improvement (several programs in active pursuit)
 - Current sharing cables mitigate piece length limitations and reduce cost

Demountable Joints Technology Assessment

- High thermal margin of HTS allows demountable joints
 - Vertical maintenance, simplification of installation and component replacement
 - Use of demountable joints would broaden design options
- Acceptable joint resistances have been demonstrated but needs more experimental work
 - Technology is fusion-specific; few external drivers
- A reasonable first demonstration would be to operate a superconducting coil at full field with low heat generation
 - Most required infrastructure already exists
 - Little global development gives US opening for leadership

Outline

- Introduction and process
- First Tier Transformative Enabling Capabilities
 - Advanced algorithms
 - High critical-temperature superconductors
 - Advanced materials
 - Novel technologies in tritium fuel cycle control
- Second Tier Transformative Enabling Capability
 - Fast flowing liquid metal plasma-facing components
- Foundational and Enabling Activities

Advanced Materials

- New material design and processes (i.e. “advanced and additive manufacturing”) enable realization of **resilient PFC and structural materials components** that are essential in harsh fusion reactor environment
- Promising advances in advanced manufacturing (e.g. spark plasma processing) and additive manufacturing are enabling **novel hierarchical material composites** resulting in multi-functional materials for harsh environments
- This TEC includes
 - Materials-by-design
 - Emergent fusion nuclear materials
 - Divertor materials
 - Complex heat transfer systems

Advanced Materials – Challenges

- Heat flux

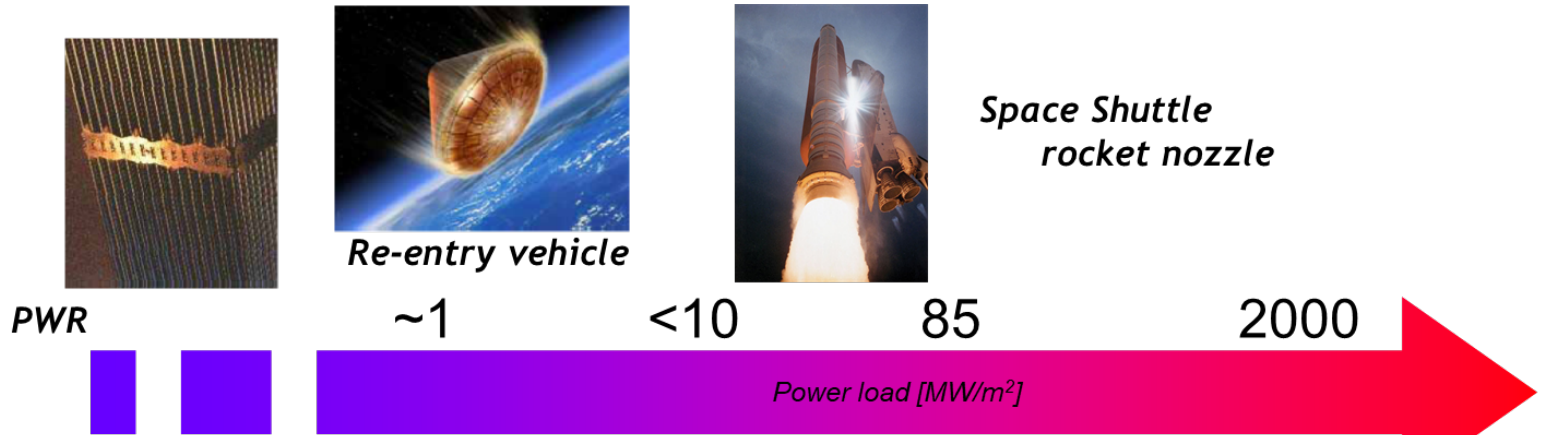

Space Shuttle rocket nozzle

Re-entry vehicle



GE90-115B

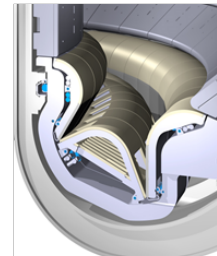

ITER steady-state

Outer divertor:
1200 C
Inner divertor:
800 C



ITER transients (1ms lifetime)

- Neutrons & He

14 MeV, high He/dpa
up to 150 dpa for blankets
up to 50 dpa for divertor

- Surface evolution

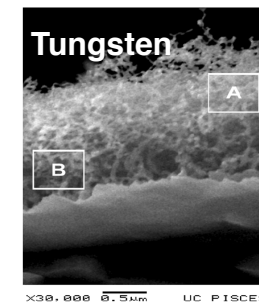

Additive manufacturing can revolutionize materials and components for fusion energy reactors

- **Promise**

- Ability to fabricate highly complex structures
- Control of microstructure for unique local properties
- Rapid design-fabricate-test cycles
- Ability to fabricate with refractory metals such as W, and other materials e.g. ODS steel
- Widespread development community



A complex lattice structure made of 316SS using an AM machine at LLNL.

- **Risk**

- Technology for fusion relevant materials very basic, unknown PMI and structural properties
- Material properties can be different than traditional materials despite being same alloy
- Qualification of materials and components can be more complex and expensive

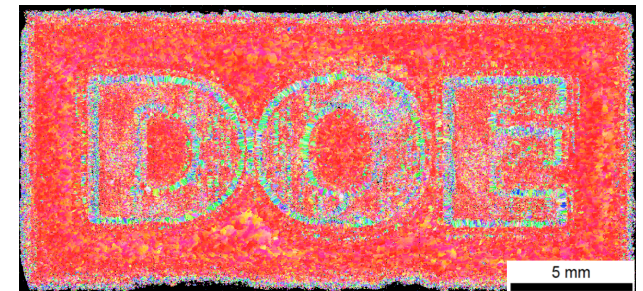

EBSD image of a nickel-based alloy showing designed microstructure orientation created by an AM machine at ORNL.

Advanced materials – Materials by Design

- Materials-by-design (MBD) combines predictive computational tools (e.g. machine-learning with robust advanced manufacturing) and synthesis approaches, such Additive Manufacturing (AM)
 - **Promise:** design of complex components and geometries, the ability to work with relevant materials such as refractory metals, and the potential for local control of microstructure at large scale
 - **Game-changer:** Desired microstructure, PMI, self-healing and radiation resistant properties, can be tailored *designed* into complex geometries and hierarchical structures addressing surface/bulk in a single graded system
 - **Risk:** The extent of MBD approaches are intrinsically dependent on advances in advanced manufacturing and AM
 - Adoption of advances in manufacturing (e.g. AM, others) in sectors outside fusion would require appropriate adaptation of process design to fusion-relevant concepts

Emergent fusion materials

- Adaptive and self-healing materials, complex hierarchical composites, complex alloys, and hybrid liquid/solid systems
 - **Promise:** Complex composites and complex alloys may provide design of radiation-resistant and radiation-tolerant materials with tailor-designed defect sink interfaces, from the PMI to bulk regions
 - defect-mediated self-healing properties
 - **Risks:** Unknown PMI properties and interface with bulk, hybrid systems with solid/liquid phases and composites have the highest risk
 - unknown materials properties, process scale-up development and unknown safety and performance margins

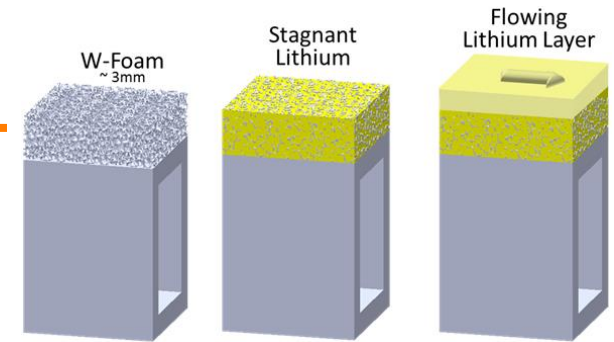

Ghoniem and Williams, 2017

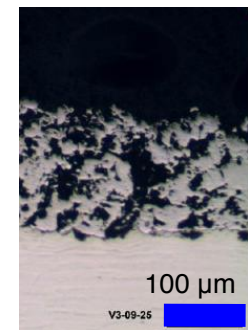

Flame spray

Rindt, PFMC 2017

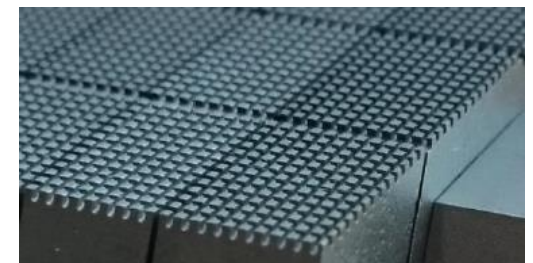

Wire EDM texture

Divertors and Complex Heat Transfer Systems

- **Promise on divertor materials:** W-based refractory composites include continuous fiber W-matrix composites, distributed or semi-interconnected W particulate composites and others
 - W foam core and other refractory metal shell/core proposed in conjunction with flowing He cooling; high $q_{\text{exhaust}} \sim 20 \text{ MW/m}^2$
- **Promise on complex heat transfer systems:** AM produces structures with sub-mm precision in meter-size components, graded material composition, and complex geometries
 - Novel combinations can address multiple functions, e.g. material fracture toughness combined with complex graded porosity for radiation resistance

Outline

- Introduction and process
- First Tier Transformative Enabling Capabilities
 - Advanced algorithms
 - High critical-temperature superconductors
 - Advanced materials
 - Novel technologies in tritium fuel cycle control
- Second Tier Transformative Enabling Capability
 - Fast flowing liquid metal plasma-facing components
- Foundational and Enabling Activities

Control of the Tritium Fueling Cycle

- Because D-T fusion power plants must self-generate their T fuel, **novel concepts for fuel production, extraction, and processing show transformative potential**
 - Fuel production: several blanket technologies will enable **higher thermal efficiency, and the efficiency by which tritium can be generated within the blanket**, both of which will significantly reduce fusion plant operating costs
 - Fuel extraction: new tritium extraction technologies from liquid metal breeding blankets promise **high extraction efficiencies > 85%**, which will maximize plant performance and safety
 - Fuel processing: a new technology may simultaneously decouple plasma and tritium plant operation **and reduce the size and inventory of the DEMO tritium plant by ~75%**

Tritium Production – DCLL Blankets

- **Challenge:** To satisfy multiple conflicting material compatibility, structural integrity, and lifetime requirements while removing heat, breeding tritium and providing a first wall
 - No blanket concepts have demonstrated the requirements for fusion power reactors
- ITER Test Blanket Module (TBM) research is one of the “unshared” areas
- DCLL: *Dual coolant lead-lithium* leading US candidate

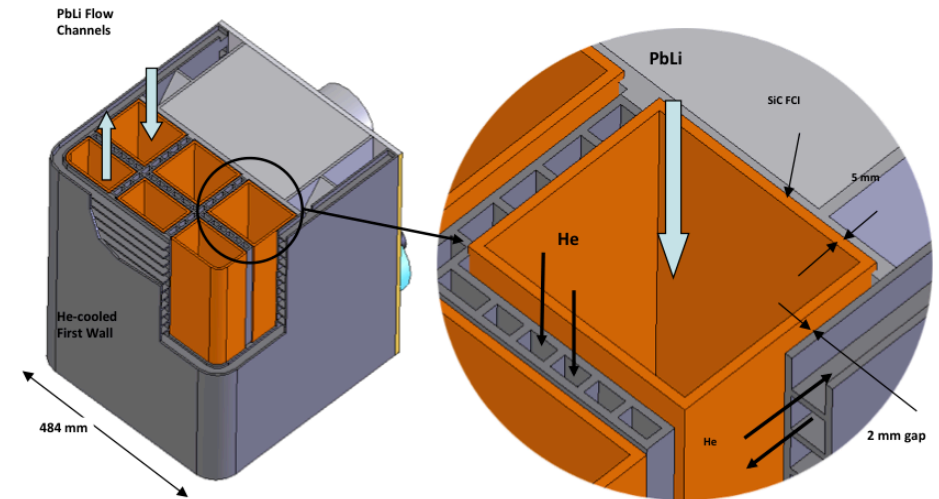

Transformative Potential:

- Blanket is an unresolved issue with high payoff: Blanket is recognized by most as the most critical integrated component for providing competitive COE
 - Potential for high tritium breeding ratio
 - Highest thermal efficiency ~45% of all ITER-scale and DEMO-relevant concepts

Tritium Production – Cellular Media Blankets

- While US favors DCLL, most blankets in ITER TBM use solid ceramic breeders
- **Promise** of Cellular Ceramics
 - Thermal conductivity substantially increased relative to pebble beds
 - High temperature sintering eliminated, and tritium breeding ratio (TBR) and breeder durability are increased
 - Replacing a pebble bed with a cellular breeder is anticipated to reduce blanket size and system cost, and **increase TBR by as much as 20%**
 - Preliminary neutronics calculations indicate that for a given TBR, overall **blanket thickness may be reduced by as much as 30- 40%** compared with pebble bed configurations

Cellular Media: A promise of precisely-crafted porosity & other attractive properties

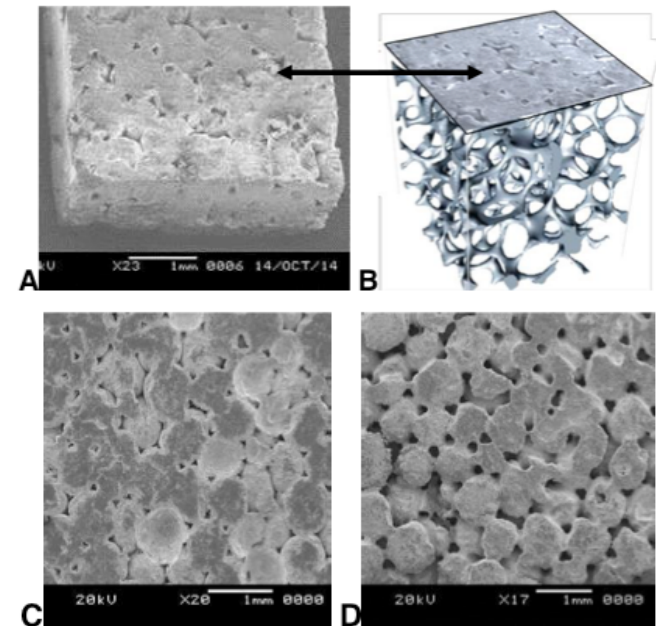

Tritium Extraction – Electrolytic Membranes

- Challenge:** Recently Li, SnLi are being proposed for flowing liquid metal (LM) first wall and divertor concepts and for use in tritium breeding blankets (PbLi) for the next step US fusion reactor
 - LM flow of these systems must be continuously processed to T levels < 10 ppm while preserving high LM temperatures (700 C)
 - No tritium extraction technologies exist for any of these LM systems
- New mechanism for Li – T separation using Li conducting electrolytic membrane: proof of concept achieved
- Another technique: use proton conducting electrolytic membrane

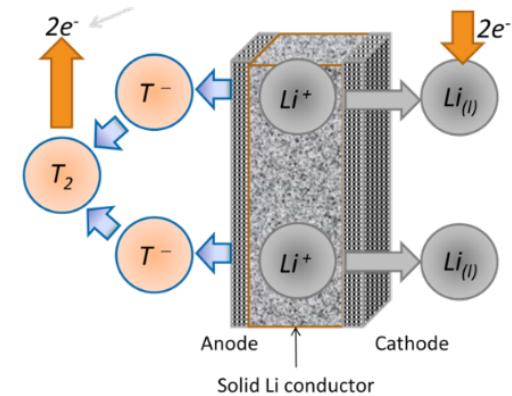
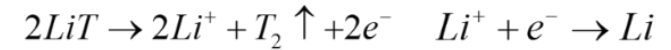

$$E_{400^\circ C}^0 = -2.82V$$

$$E_{400^\circ C}^0 = -3.22V$$

Schematic of SRL's Lithium Conducting Electrolytic membrane

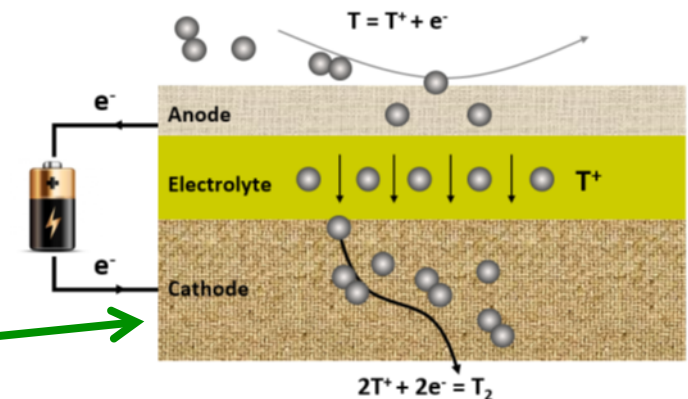

Schematic of INL's Proton Conducting Electrolytic membrane

Tritium Extraction (cont.) – Vacuum Permeator

- Extraction efficiency from LMs limited by mass transport of tritium from the bulk of the LM to the surface of the extraction membrane

- Vacuum permeator: use a Group 5 metallic membrane to push the T towards the membrane's surface

- Potential of processing the entire liquid metal flow at operating temperature with an extraction efficiency $> 85\%$, but doesn't work well for liquid lithium

- A combination of all three technologies promises to fill the technology gap by producing extraction technologies for each of the LM systems

- If used in combination, for example a ceramic electrolytic proton conducting membrane in a vacuum permeator, **an extraction technology emerges that will work for any LM**

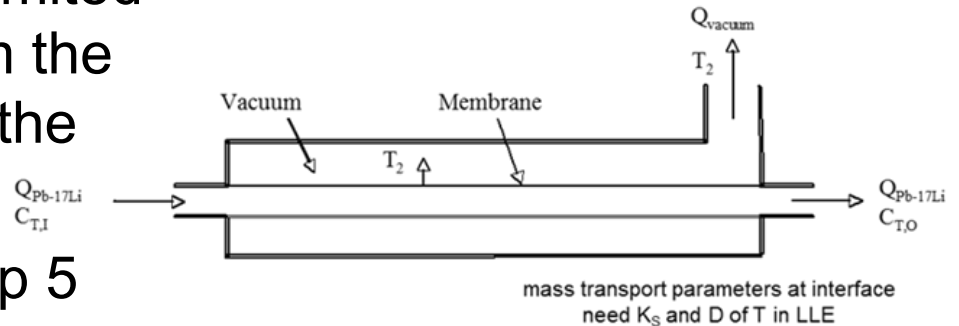

Tritium Processing

- **Challenge:** A driver of both the fueling plant's tritium inventory and processing rate is tritium burnup fraction (TBF): ITER and EU DEMO at ~0.35% to 1.5%

- DEMO Tritium Plant 4x larger than ITER

- Metal Foil Pump decouples TBF from tritium plant operation

- **Promise:**

- Potential to reduce the Tritium Plant D+T throughput by 75%
- Steady state operation, unlike the cyclic operation of cryopumps
- Does not require cryogenic cooling, large pumping ducts or to be isolated from the VV by large valves during regeneration
- Operates at high temperatures, can be located close to the plasma, and does not have the large D+T inventory associated with cryopumps

RFNC-VNIIEF Prometheus MFP

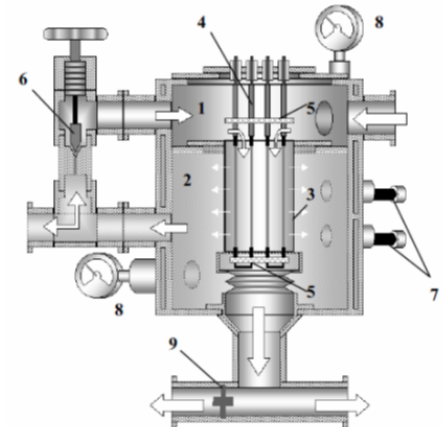

Fig.1. The cell of "Prometheus" setup for study of superpermeation of hydrogen isotopes: 1- inlet chamber; 2- outlet chamber; 3- cylindrical membrane; 4- atomizer; 5- quartz disks; 6- leak valve; 7- pyrometer; 8- pressure gauge; 9- diaphragm

Outline

- Introduction and process
- First Tier Transformative Enabling Capabilities
 - Advanced algorithms
 - High critical-temperature superconductors
 - Advanced materials
 - Novel technologies in tritium fuel cycle control
- Second Tier Transformative Enabling Capability
 - Fast flowing liquid metal plasma-facing components
- Foundational and Enabling Activities

Fast flowing liquid metal plasma-facing components

- Fast flowing liquid metal plasma facing components may prove to be an attractive alternative to handle both high steady state and transient plasma heat flux in a fusion reactor power plant, which would revolutionize control of the plasma-material interface
 - Fast flow means $\geq 1\text{m/s}$
 - Slow-flow $\leq 10\text{ cm/s}$ considered in advanced materials as hybrid systems
 - Can be conceptually applied to the wall and/or divertor

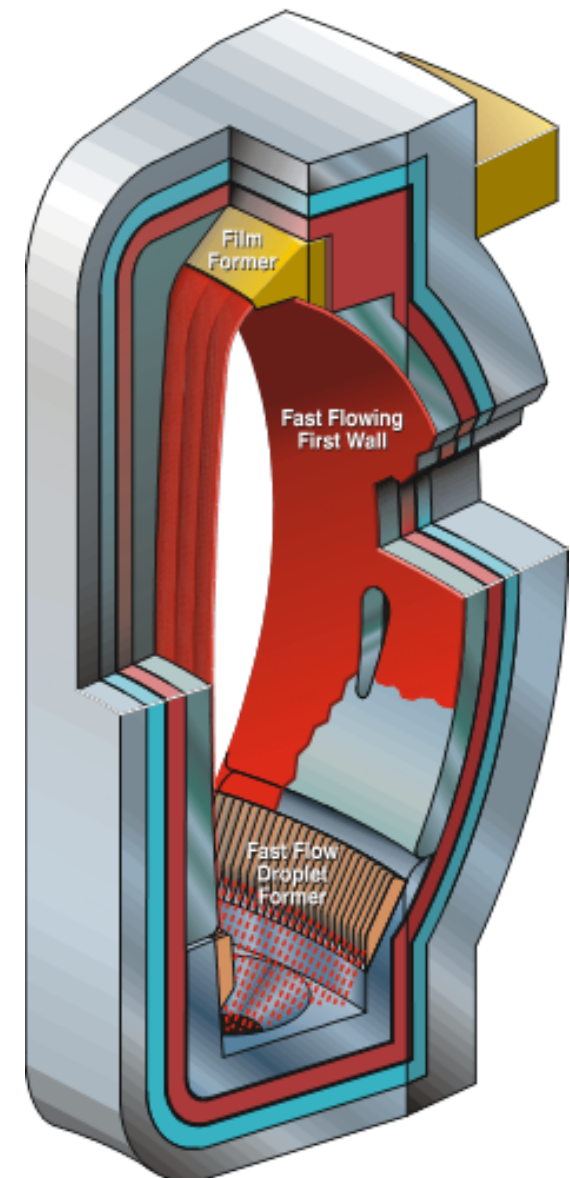

Promises of fast flowing liquid metal plasma-facing components

- **Promise:** supplement heat conduction through the substrate with heat convection via liquid metal flow
 - Very high steady, and transient heat exhaust
 - Tolerable PFC erosion: self-healing surfaces
 - No dust generation
 - Eroded chamber material from the main chamber transported to the divertor could be removed via liquid flow
 - Neutron/dpa tolerance; underlying substrate would still have neutron-induced modifications, though
 - Substrates below LM are protected from plasma-material interactions
 - Liquid lithium offers high confinement

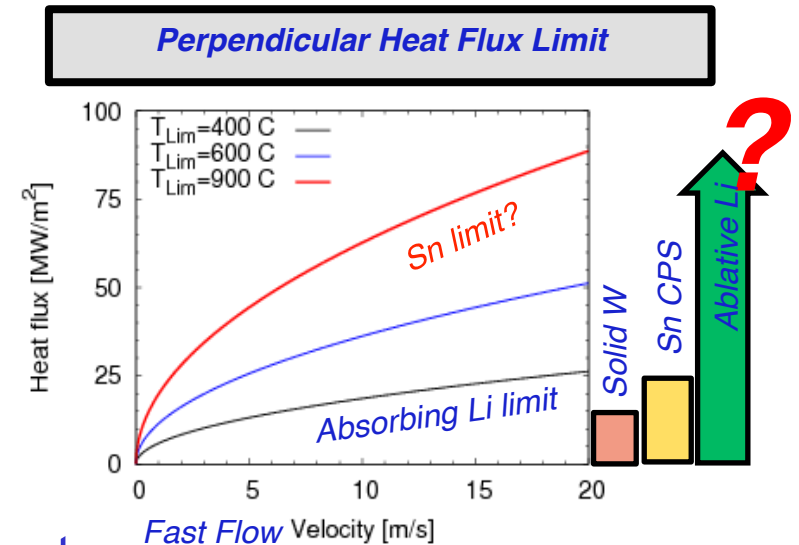

Challenges of fast flowing liquid metal plasma-facing components

- Reliably producing stable LM surfaces and flows
- Understanding and controlling the LM chemistry
- Acceptable temperature windows for specific integrated scenarios: choice of substrate/coolant that is able to provide for LM surface temperature control
- Fuel retention, recycling and removal in candidate liquid metals
- Corrosion issues involving large quantities of LM interfacing with substrate/bulk components at high temperatures
- Wetting vs dry-out effects asymmetric over substrate materials
- Neutron damage of solid-based substrate materials
- Understanding application of LM to a divertor vs. the first wall
- Plasma confinement with liquid metal PFCs at reactor scale

Outline

- Introduction and process
- First Tier Transformative Enabling Capabilities
 - Advanced algorithms
 - High critical-temperature superconductors
 - Advanced materials
 - Novel technologies in tritium fuel cycle control
- Second Tier Transformative Enabling Capability
 - Fast flowing liquid metal plasma-facing components
- Foundational and Enabling Activities

Foundational and Enabling Activities

- In addition to the identified TECs, a number of activities were identified as foundational on the path toward a fusion reactor, but not transformative
- That is, these capabilities are necessary, and the development of a fusion power plant probably cannot happen if we do not continue to develop them
- Also, we identified needed testing facilities to evaluate progress from certain TECs

Foundational and Enabling Activities

- Novel measurements
 - Need for radiation hardened diagnostics
- Current drive
 - Injection of EM waves, neutral beams, and helicity
- Disruption control and mitigation actuators
 - Shattered pellets, shell pellets, electromagnetic particle injector
- Exascale computing
 - Contributes to high fidelity simulations; design optimization and uncertainty quantification; and operations & control

Foundational and Enabling Activities (continued)

- Advanced divertor concepts
 - Shape optimization, magnetic variations (“snowflake” and “super-X” and other concepts)
- Tritium and lithium safety
 - Present leading concepts for tritium extraction (molten salt mix + centrifuge), processing (TCAP), and computational tools (MELCOR)
- Advanced power extraction techniques
 - Supercritical CO₂ Brayton cycle with thermal efficiency up to 60%
- Foundational program areas and test beds
 - Need for HTS testing facilities, advanced material testing facilities, and fuel cycle development facilities

Summary

- Panel identified several promising Transformative Enabling Capabilities “*that could promote efficient advance toward fusion energy, building on burning plasma science and technology.*”
- First Tier Transformative Enabling Capabilities
 - Advanced algorithms
 - High critical-temperature superconductors
 - Advanced materials
 - Novel technologies in tritium fuel cycle control
- Second Tier Transformative Enabling Capability
 - Fast flowing liquid metal plasma-facing components
- Each of these presents a huge opportunity to accelerate fusion science & technology toward power production!

Backup

FESAC TEC Community Input Meeting, May 30 – June 1

Technology Assessment “Checklist”

The assessment of each technology application should have the following components:

1. Description of the technology
2. Application of the technology
3. Critical variable(s) – variable(s) that determines or controls the output of the technology
4. Design variables – parameters that can be controlled in order to optimize the critical variable
5. Risks and uncertainties with technology development and performance
6. Current maturity of the technology
7. Technology development for fusion applications
8. Other considerations / broader impact

FESAC TEC Community Input Meeting, May 30 – June 1

Technology Readiness Levels

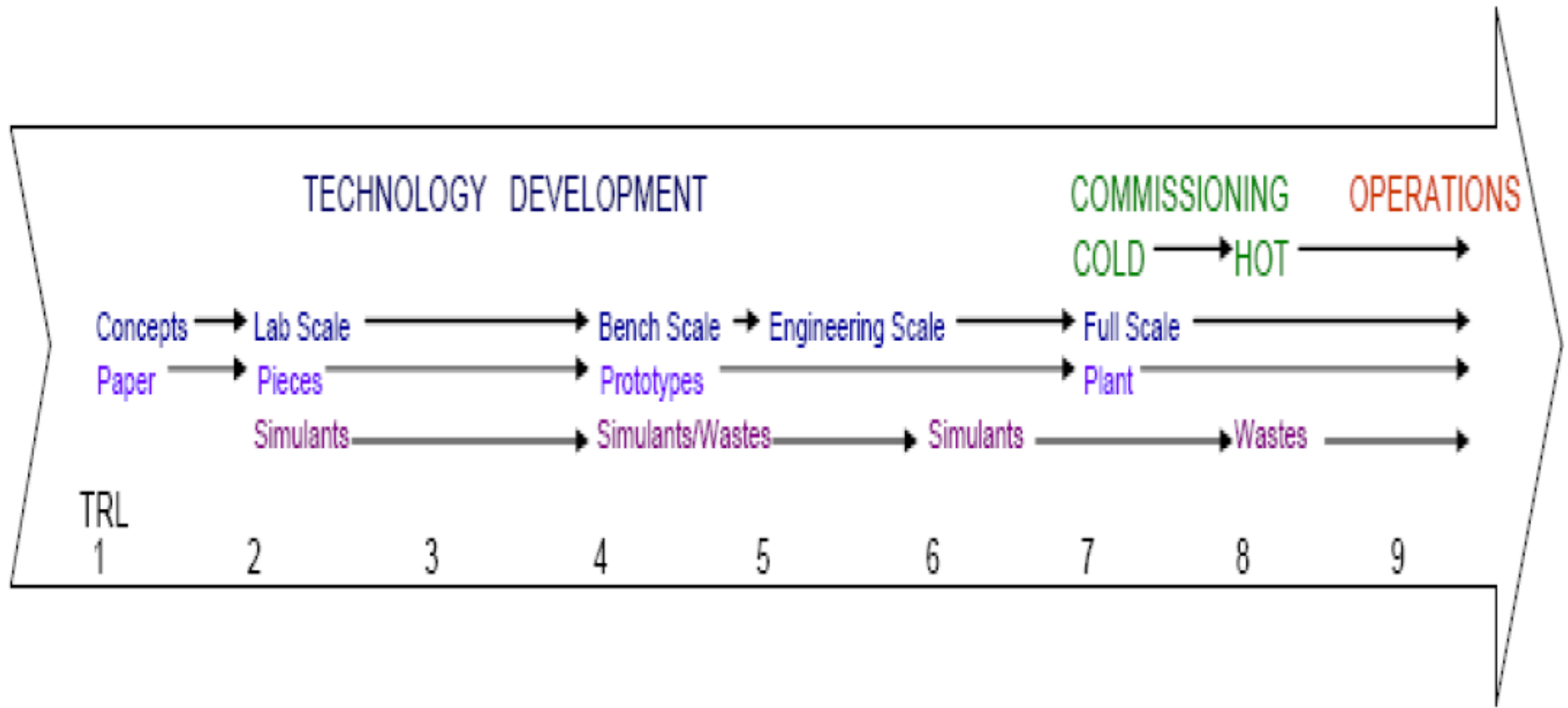

•From DOE G 413.3-4A , Technology Readiness Assessment Guide

FESAC TEC Community Input Meeting, May 30 – June 1

Technology Readiness Levels

- TRL 1 – pure research
- TRL 2 – applied research
- TRL 3 – laboratory testing of individual components
- TRL 4 – laboratory testing of integrated components
- TRL 5 – field testing of integrated components (lab scale)
- TRL 6 – field testing of scale prototype
- TRL 7 – full-scale testing of prototype in cold conditions
- TRL 8 – system completed and qualified through test and demonstration
- TRL 9 – Actual system operations in full range of conditions

FESAC TEC Community Input Meeting, May 30 – June 1

Technology Readiness Levels

TRL Level	Scale of Testing	Fidelity	Environment	Development
9	Full	Identical	Operational (Full Range)	System Operations
8	Full	Identical	Operational (Limited Range)	System Commissioning
7	Full	Similar	Relevant	
6	Engineering / Pilot Scale	Similar	Relevant	Technology Demonstration
5	Lab / Bench	Similar	Relevant	Technology Development
4	Lab	Pieces	Simulated	
3	Lab	Pieces	Simulated	Feasibility Research
2		Paper		
1		Paper		Basic Technology Research

Technology Assessment List

1. Technology to be assessed
2. Application of the technology (Note – while the application presented may be useful for a variety of different machines, it must be applicable to a tokamak or stellarator concept).
3. Critical variable(s) – variable that determines or controls the output of the technology
 - What is the goal for transformative technology – anticipated value or range of values for critical variable that needs to be achieved?
 - What is the range that is achievable for current state of technology?
4. Design variables – parameters that can be controlled in order to optimize the critical variable. These could be qualitative.
 - Give a description of values that are currently achievable, and a description of what needs to be explored in order to achieve transformation.

Technology Assessment List

5. Risks and uncertainties

- What are the inherent constraints on the technology (such as, limits that are based on physical laws)? What are the uncertainties in the calculations of steps 3 & 4?
- What are the engineering questions and issues (manufacturability, go / no go issues, etc.). Are there any inherent safety issues?
- Are there institutional, regulatory, or societal obstacles to the development or use of this technology? Is there resistance to the use of this technology in the scientific community, or in the relevant industries?

6. Maturity

- What progress has been made in this technology in the last 20 years and what is the projected development rate?
- What is the technology readiness level for the application?

Technology Assessment List

7. Technology development for fusion applications

- What is required to bring this technology to TRL3 and TRL6? How many simultaneous innovations are required for this technology to achieve the goal?
- What is the time horizon for this technology to achieve the goal for the application?
- What resources, public and private, are currently available to develop this technology? Will developments in this technology from other sources be useful for the requirements of the application?
- (How) are other nations, through government or private sources, developing this technology? Are there gaps in global development that represent possible opportunity for US investment?

Technology Assessment List

8. Other considerations / broader impact

- What is the larger impact that this technology would have on the power plant (to make a particular power plan more attractive, to improve technologies that it would interface with)?
- What other technologies could serve as an aid to, or a replacement for, this technology? What other fields or technologies could be explored that could meet the requirements of the application?

Evaluation Metric (1)

- Impact (as compared to current conventional technology)
 - TECE will reduce cost (development cost, construction cost, or operational cost) of FPP.
 - TECE will accelerate schedule to FPP.
 - TECE will improve safety, maintainability or public acceptance of FPP.
 - TECE is novel, has high reward / risk ratio.
 - TECE will remove major risk to completion of FPP.
- Risks and uncertainties
 - Engineering questions and issues (manufacturability, go / no-go issues) are well-defined and understood.
 - TECE has no serious safety concerns.
 - TECE element has no institutional, regulatory, or societal obstacles to its development.

Evaluation Metric (2)

- **Maturity and development**
 - Current maturity level and development rate of TECE.
 - Simultaneous innovations are not required to bring TECE to maturity.
 - Cost required to bring TECE to TRL6 is reasonable.
 - Time horizon to bring TECE to TRL6 is reasonable.
 - Prospect for rapid development from sources outside of fusion
 - The US has opportunity to take global leadership in this TECE.
- **Broader impact**
 - TECE makes the FPP more attractive.
 - TECE improves performance of interfacing technologies.